

(No Model.)

3 Sheets—Sheet 1.

H. M. ALBEE.
WOODWORKING MACHINE.

No. 505,805.

Patented Oct. 3, 1893.

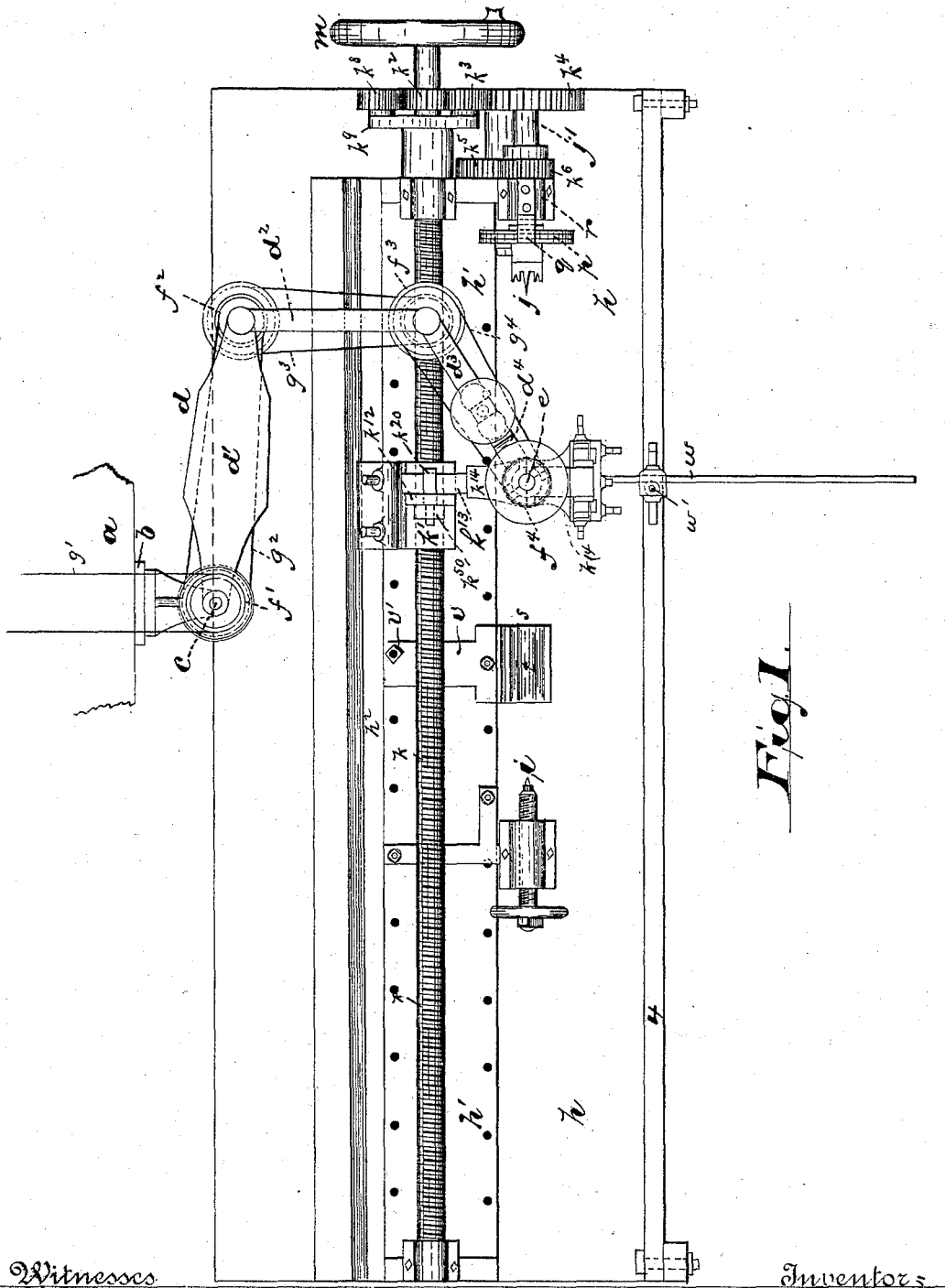

Fig. 1.

Witnesses

Inventors

Oscar A. Michel
E. Tyler

Honestus M. Albee.

By Drake & Co. Atty's.

H. M. ALBEE.
WOODWORKING MACHINE.

No. 505,805.

Patented Oct. 3, 1893.

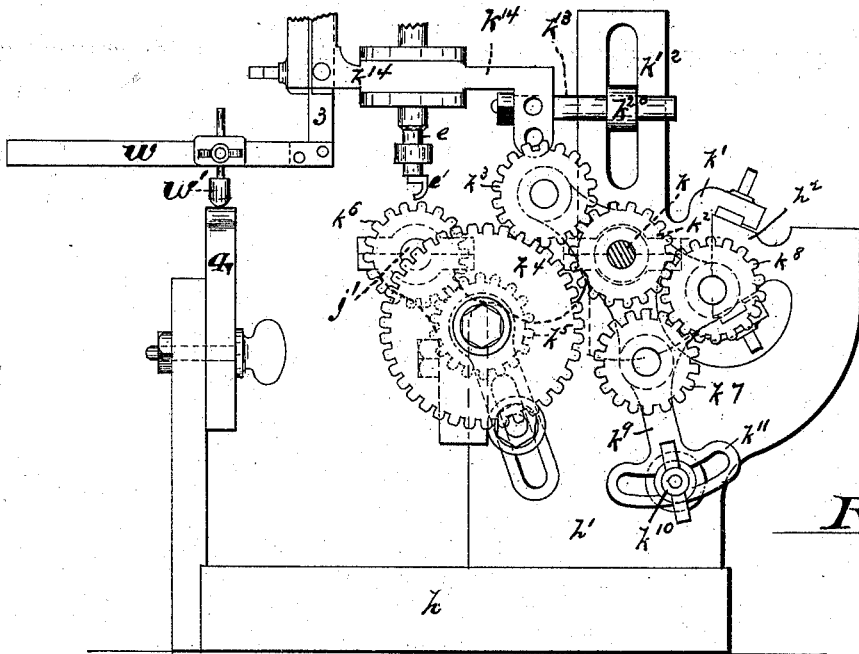

Fig. 2.

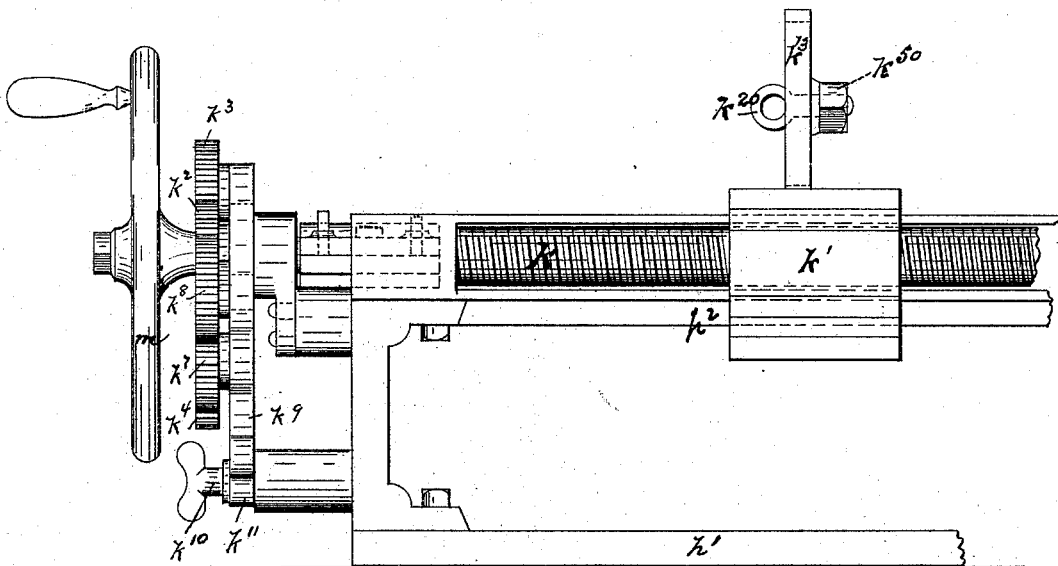

Fig. 3.

Witnesses

Inventors

Oscar A. Michel
E. Igler

Honestus M. Albee,

By Drake & Co. Attys.

H. M. ALBEE.
WOODWORKING MACHINE.

No. 505,805.

Patented Oct. 3, 1893.

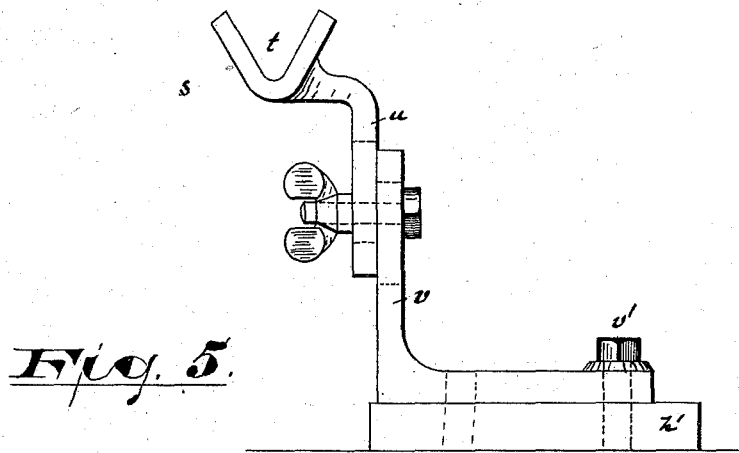
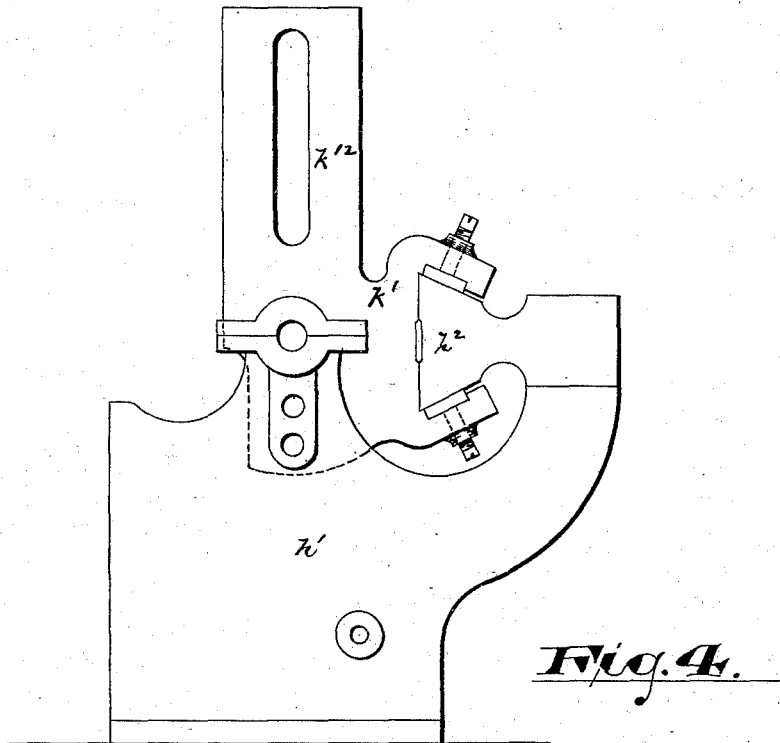

Witnesses

Inventor:

Oscar A. Michel,
E. J. Iyer

Honestus M. Albee,

By Drake & Co. Attys.

UNITED STATES PATENT OFFICE.

HONESTUS M. ALBEE, OF NEWARK, NEW JERSEY.

WOODWORKING-MACHINE.

SPECIFICATION forming part of Letters Patent No. 505,805, dated October 3, 1893.

Application filed June 9, 1891. Serial No. 395,656. (No model.) Patented in England August 17, 1891, No. 13,864; in Belgium August 31, 1891, No. 96,103; in France December 4, 1891, No. 215,601; in Germany June 14, 1892, No. 62,889, and in Canada February 2, 1893, No. 41,789.

To all whom it may concern:

Be it known that I, HONESTUS M. ALBEE, a citizen of the United States, residing at Newark, in the county of Essex and State of New Jersey, have invented certain new and useful Improvements in Woodworking - Machines; and I do hereby declare the following to be a full, clear, and exact description of the invention, such as will enable others skilled in the art to which it appertains to make and use the same, reference being had to the accompanying drawings, and to letters and figures of reference marked thereon, which form a part of this specification.

This invention relates to certain improvements in that class of machines for cutting or carving spiral grooves in the peripheral surfaces of wooden sticks, illustrated in my United States Patent No. 408,366.

For this present invention, subsequent to the filing of the application but before the issuing of this patent, I have received patents in foreign countries as follows: England, No. 13,864, dated August 17, 1891; Belgium, No. 96,103, dated August 31, 1891; France, No. 215,601, dated December 4, 1891; Germany, No. 62,889, dated June 14, 1892, and Canada, No. 41,789, dated February 2, 1893.

The objects of the present improvements are to facilitate the operation of cutting reverse spirals, to secure greater perfection in the work, to provide against vibration when turning spirals on sticks of comparatively large size and to secure other advantages and results, some of which will be set forth in connection with the description of the working parts.

The invention consists in the improved wood working machine and in the combinations of parts thereof substantially as will be hereinafter set forth and finally embodied in the clauses of the claim.

Referring to the accompanying drawings, in which like letters and figures indicate corresponding parts in each of the several views, Figure 1 is a plan of the machine. Fig. 2 is an end view and Fig. 3 a rear view of certain reversing mechanisms, and Fig. 4, a detail showing more clearly the construction and arrange-

ment of a certain carriage. Fig. 5 is a detail side view of a stick holder, rest or support.

In said drawings, *a*, Fig. 1, indicates a suitable fixture or support for a bracket, *b*, carrying pivotal bearings, *c*, for a vibrating arm *d*. Said arm consists of pivoted sections *d'*, *d''*, *d'''*, and, at the outer end of the section, *d''*, a vertically adjustable section, *d''''*, which last provides bearings for a rotary shaft, *e*. Said shaft carries a rotary carving or routing tool *e'*. At the joints in the sectional arm, and on the rotary tool shaft, are pulleys *f'*, *f''*, *f'''*, and *f''''* and these are connected by belts, *g'*, *g''*, *g'''*, *g''''*, with any suitable motor or source of power, so that rotary motion will be imparted to the shaft, *e*, and tool carried thereby, all as will be understood.

Below the plane of movement of the vibrating arm and its tool, on a suitable table or support, *h*, is arranged a lathe, between the centers, *i* and *j*, of which, the wooden piece to be turned and ornamented with a spiral or other desirable ornamentation may be arranged, and back of said centers is a screw shaft, *k*, which is geared to the shaft *j'*, of the center *j*, by a train of gearing *k''*, *k'''*, *k''''*, *k''''''*, shown more clearly in Fig. 2, by means of which the screw shaft and the center, *j*, and the wooden piece carried thereby, are caused to turn simultaneously at proportional rates of speed, the movement of the screw shaft governing the movement of the wooden piece worked upon, as will be understood.

On the screw shaft is arranged a carriage, *k'*, which slides longitudinally upon the plate, *h'*, of the table, its movement being induced by the rotation of the screw shaft. To this carriage is attached the vibrating arm and rotary carving tool by means of a bar, *k''*, the said tool being held thereby in a position to engage the turning stick or wooden piece. By turning the hand wheel, *m*, on the screw shaft, (power being applied to the rotary carving tool) the stick is caused to revolve slowly with the center, *j*, and the carriage, *k'*, is forced to move longitudinally, carrying the carving tool on the jointed arm with it and, as a result, a spiral groove is cut in the stick. It frequently happens, however, in orna-

mental wood work, that two sets of spirals are desired, pitched in opposite directions, the oppositely pitched grooves being in one and the same stick, giving a diaper effect to the ornamentation or the said oppositely pitched grooves being in separate pieces.

To secure a reversely pitched cut quickly and accurately, is one of the important features of the present improvement. To this end, I provide means for reversing the direction of pivotal movement of the stick in its relation to the screw shaft. This is accomplished by means of a vibratory frame or plate k^9 , Figs. 2 and 3, pivoted or centered on the shaft, k , and having, at suitable points thereon, gear wheels k^8, k^7 , adapted to engage with the wheel, k^4 , of the train of gearing and be disengaged therefrom alternately, as will be understood. The wheel, k^3 , receives its power directly from the gear wheels, k^2 , on the shaft, k , while the wheel, k^7 , receives its power from the said wheel, k^2 , mediately or through the intermediate gear wheel, k^8 , so that its movement will be in a reverse direction from the wheel, k^3 , and will thus communicate reverse movement to the wheel k^4 and the wooden piece geared thereto. The adjustable frame or plate, k^9 , is held in either of the two positions of operation, by means of a set screw, k^{10} , which works in a slotted extension k^{11} .

In connection with the lathe center j , I have provided a gage disk, p , which turns on the same pivotal shaft with said center and the gear or cog wheel k^6 as shown only in Fig. 1. The periphery of said disk is divided off by equi-distant graduations, say six, eight or ten, dividing the periphery into sixths, eighths or tenths, or the said periphery, may be, and preferably is, divided circumferentially as shown, one of the subdivisions having six graduations enabling the workman to readily make six cuts or grooves at proper distances apart on the stick, the second subdivision having eight and the third ten graduations as will be readily understood.

Adjacent to the graduated or marked periphery of the disk, p , is a fixed or stationary index, q . This is preferably secured upon the box or bearing r , for the shaft referred to in connection with the center j .

By means of the gage arranged as described, the longitudinal or spiral grooves may be quickly and accurately spaced on the stick. In operating this device, the first groove may be started on the periphery, the index coinciding with an initial graduation of either one of the series desired. As the stick revolves and the spiral groove is being cut, the disk also revolves and when the next graduation mark arrives at the index, the tool may be raised out of the first spiral groove and brought again to the end of the stick and a second groove started at a proper point regulated by the index and this may be continued until the stick has the requisite number of properly spaced grooves.

In the prior device, above referred to, it may be observed that a stick holder is provided, consisting of jaws adjustable in relation to one another by means of adjusting screws and movable with the carriage. Such a device is desirable more particularly and especially in connection with very small work of a certain class requiring bearing close to the routing tool. For larger work, I have provided a holder or rest s , shown more clearly in Fig. 5, consisting of a V-shaped head t , so that the round and either parallel sided or tapered stick will have two bearings in the holder at opposite sides of a longitudinal and vertical central plane through the stick. The said head has a leg, u , which is adjustably secured to an adjustable stud, v , arranged on the bed or plate, h' , of the table, being held thereon by set screws, v' adapted to admit of a ready change of position in accordance with the necessities of the work. Thus the V-shaped head may be raised or lowered, adjusted longitudinally with respect to the stick and changed in angle to correspond, for example, with a taper in a baluster.

To enable either large or small sticks to be operated upon and to regulate the depth of the groove in the stick, without changing the gear wheels and centers of the lathe, and to secure peculiar effects in carving in accordance with a desired pattern, I have made the carving or routing tool vertically adjustable in its bearings, the adjustment being controlled by a guide rod, w , and tracing tool, w' , adjustably arranged on said rod, and the latter being attached to a vertically sliding plate 3 which controls the vertical movement of the tool shaft, as described particularly, in a cotemporaneous specification or in any other suitable manner. By raising or lowering the pattern, 4 , or by varying the upper bearing surface of said pattern, giving the same a waved surface for example, the depth of the spiral groove will be correspondingly varied. If the work to be operated upon be very large and beyond the limits of vertical adjustment of the tool shaft, then I may lower the table, h , in any suitable manner, (the means for doing so not being shown, the same being old,) to admit of the introduction of the said large work to the centers. To do this and yet secure the proper connection and support of the vibrating arm with the carriage, k , and bed plate h' , I have made the connections vertically adjustable as shown in the drawings, where h^2 , indicates an elevated track at the rear of the plate, h' , on which the said carriage slides horizontally when forced by the screw shaft k .

k^{12} indicates a vertically slotted arm of said carriage; k^{20} a clamp adapted to receive a bar or extension, k^{13} , of a plate, k^{14} , which controls the movement of the vibrating arm and furnishes a bearing for the vertically sliding plate 3. When the table, h , is to be lowered, the clamp, k^{20} , is first loosened to admit of the lowering of the table and lathe and after-

ward the parts k^{12} k^{20} k^{13} are again brought into rigid connection by the nut k^{50} .

Having thus described the invention, what I claim as new is—

5 1. The improved wood working machine, combining therein a jointed arm, carrying at the end thereof a rotary routing tool, and means for operating the same, a screw shaft controlling the movements of said arm, and a lathe arranged below the plane of movement
10 of said jointed arm, a train of gearing connecting said lathe and screw shaft, and an adjustable plate or frame, k^9 , carrying at one end a wheel, k^8 , of said train of gearing and,
15 at the other, wheels k^7 , k^8 , and means for holding said frame stationary, substantially as set forth.

2. The improved wood-working machine, combining therein a jointed arm carrying a
20 routing or carving tool, and means for operating said tool, a screw-shaft controlling the movement of said arm, a lathe, a train of gearing embracing adjustable wheels for reversing the movement of the lathe in its re-
25 lation to the screw shaft, substantially as and for the purposes set forth.

3. The improved woodworking machine herein described in which is combined with
30 a lathe having centers disposed in a given horizontal plane and adapted to receive a stick and rotate the same while lying longitudinally in said horizontal plane, a jointed arm disposed adjacent to said lathe and carrying a rotary routing tool, and means for operating said tool, a screw shaft lying adjacent
35 to said lathe parallel with the line of said lathe centers and the axis of the stick rotating therebetween, a carriage connected with and governing the jointed arm whereby the
40 said routing tool is caused to move horizontally parallel with the axis of the stick and produce a spiral groove in the sides thereof, a tracing tool and connections governing the

vertical movement of the said tracing tool and means for operating the lathe all substantially
45 tially as set forth.

4. In combination a sectional pivotally jointed and horizontally movable arm carrying a routing tool and means for operating the same,
50 a lathe having centers horizontally in line between which the work may be arranged, a screw shaft arranged parallel with the horizontal line of said centers and geared to move with said lathe and a carriage arranged on the screw shaft and connected with said jointed
55 arm and adapted to draw the same horizontally parallel with the line of the lathe centers and the routing tool longitudinally with respect to axis of the turning stick between said centers substantially as set forth. 60

5. In combination with the lathe, screw shaft and elevated track, h^2 , and means for turning the lathe and screw shaft, a vibrating arm carrying the rotary cutter, means for operating
65 said screw-shaft and track and having a vertically slotted arm k^{12} , a clamp, k^{20} , a bar or extension, k^{13} , extending into engagement and controlling the vibrating arm and adapted to be clamped to said arm k^{12} , substantially as
70 set forth.

6. In combination with the jointed arm and its rotary tool, and means for operating the same, a screw shaft, a carriage, k' , thereon, and sliding on a track, h^2 , and connected with
75 said arm, and provided with a slotted arm, k^{12} , a clamp, k^{20} , and connections engaging and controlling the said jointed arm and its tool, substantially as set forth.

In testimony that I claim the foregoing I
80 have hereunto set my hand this 14th day of April, 1891.

HONESTUS M. ALBEE.

Witnesses:

CHARLES H. PELL,
OSCAR A. MICHEL.